

Semi-auto Mounting Press

MA/MA-E3



Instruction



Operation video

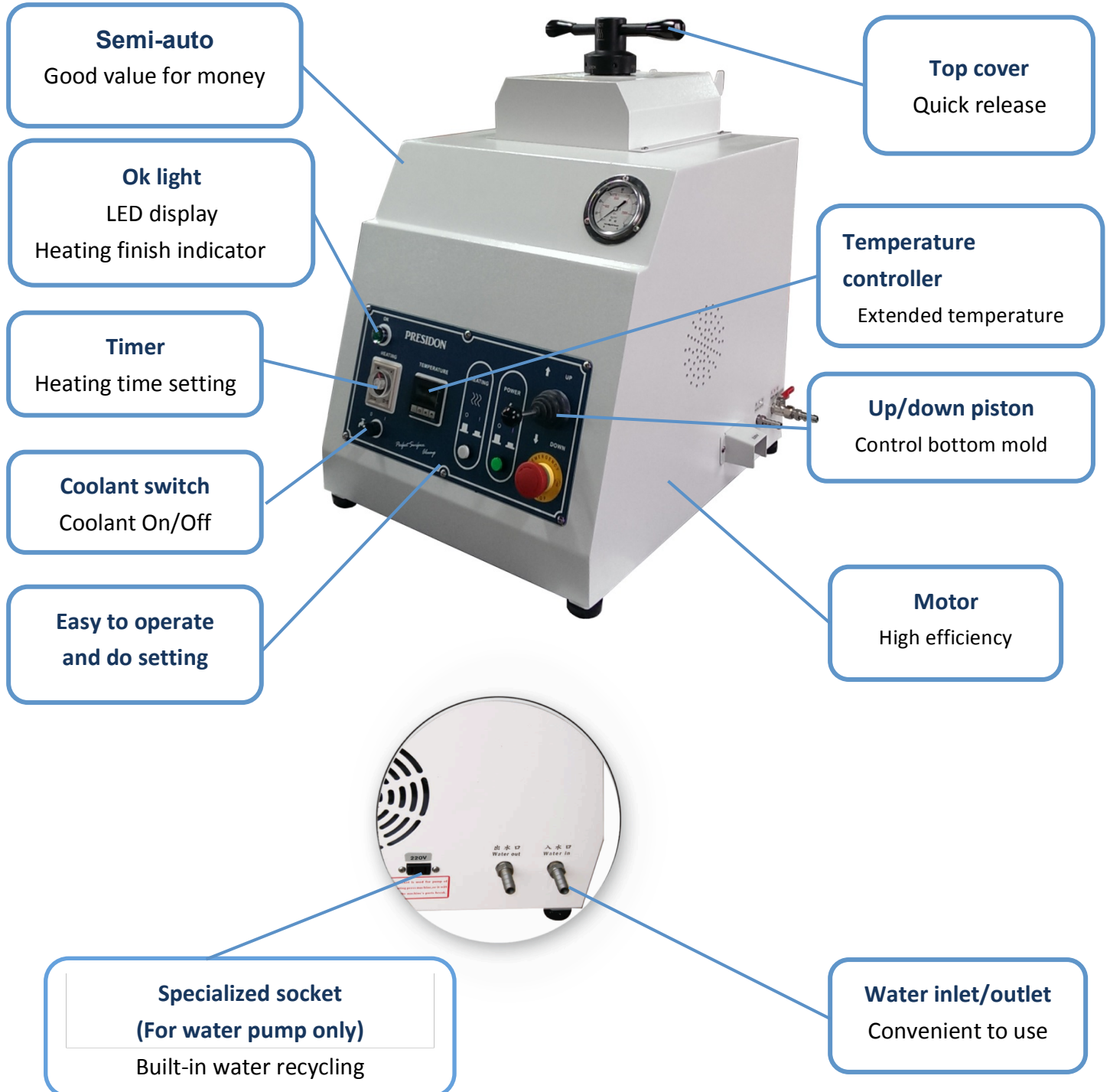

Features

Molds

Ø25

Ø32

Ø40

Ø50

Option

Cylinder kit
(Appendix 2)



Option



Coolant pump

Order no.	Spec.
QWP06001	1Ø-110V-50/60HZ
QWP06002	1Ø-220V-50/60HZ
QWP06002-1	1Ø-200V-50/60HZ

Panel Illustration

Pressure adding suggestions: 60 kg/cm^2
Not lower than 30 kg/cm^2



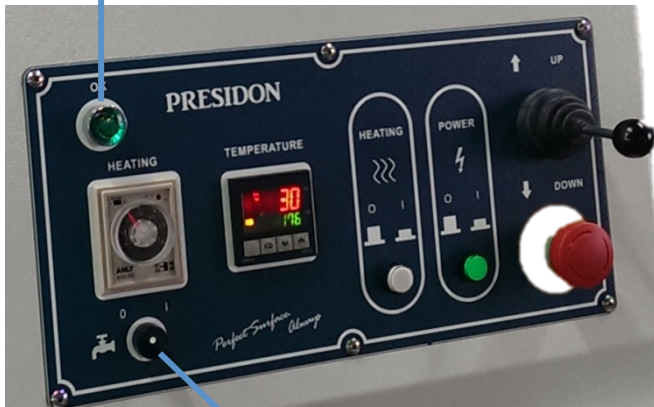

Ok light on after heating



Add pressure manually while
pressure lower than 60 kg/cm^2
during operation.

Turn on the water after heating

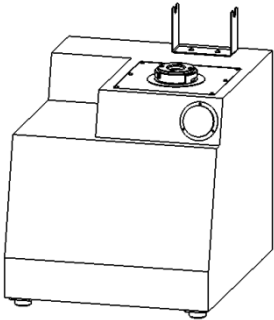
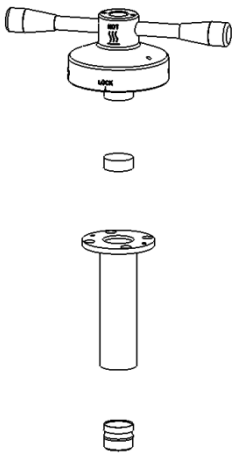
Appendix 1 Cylinder kit option

			Top cover set		
			Spacer		
			Cylinder		
			Bottom ram		
Ø40					
Cylinder kit (Single mold)	Size	Ø25	Ø30	Ø32	Ø40
	Order no.	ML40AD0215A	ML40AE0214A	ML40AE0213A	-
Cylinder kit (Three molds)	Size	Ø25	Ø30	Ø32	Ø40
	Order no.	ML40AE0215A	ML40AE0214A	ML40AE0213A	-
Ø50					
Cylinder kit (Single mold)	Size	Ø25	Ø30	Ø32	Ø40
	Order no.	ML50AE0216A	ML50AE0215A	ML50AE0214A	ML50AE0213A
Cylinder kit (Three molds)	Size	Ø25	Ø30	Ø32	Ø40
	Order no.	ML40AD0215A	ML40AE0214A	ML40AE0213A	ML40AD0215A
<p>Note 1: Cylinder kit including follow parts. Single mold: Top cover set 、 Spacer x 1 、 cylinder 、 Bottom ram Three molds: Top cover set 、 Spacer x 2 、 cylinder 、 Bottom ram</p> <p>Note 2: Special specification can be ordered.</p> <p>Note 3: Cylinder size below Ø32mm not able to option inside mold.</p>					
					

Appendix 2 Option accessories

Spacer

	Specification	Order on.	
		Copper spacer	Iron spacer
Metric (mm)	Ø25	ML25AE0210-1	ML25AE0210-2
	Ø32	M32C0006-1	M32C0006-3
	Ø38	-	-
	Ø40	M40C0006-1	M40C0006-2
	Ø50	ML50DG0210-1	ML50DG0210-2
Inch (in)	1"	-	M25AE0211
	1 $\frac{1}{4}$ "	M32C0011	M32C0011-1
	1 $\frac{1}{2}$ "	ML38AE0206	ML38AE0206-1
	2"	-	-
Remark	Special sizes can be customized		

Water pump

Order on.	Specification	Remark
QWP06001	1Ø-110V-50/60HZ	
QWP06002	1Ø-220V-50/60HZ	
QWP06002-1	1Ø-200V-50/60HZ	



Specification

Model No.	MA				MA-E3			
Sample dia.	Ø25mm	Ø32mm	Ø40mm	Ø50mm	Ø25mm	Ø32mm	Ø40mm	Ø50mm
Driven method	Hydraulic							
Sample dia.	1pc/per time - Note 1				1~3pc/per time			
Temperature	0~250°C - Note 2							
Noise level (idle running)	62~73dB		63~75dB		65~75dB		66~76dB	
Heating power	1200W		1600W		2400W		3200W	
Motor power	1760W		2160W		2960W		3760W	
Heating time	Max.30 minutes							
Cooling	Turn on the water switch after heating until temperature drop to the room temperature							
Pressure adding	60 kg/cm ² (852psi)							
Machine Dimension (WxDxH)	50x59x65cm				50x59x71cm			
Machine Weight	65Kg		66Kg		68Kg		71Kg	
Water inlet/outlet pipes	10mm pipes (inner dia.Ø10mm□Outer dia.Ø15mm)							
Cooling System	Connect to water pump for cooling recalculation							
Power supply	AC220V-1 Ø (Special voltage can be ordered)							
Standard accessories	Tweezer□1pc		Funnel□1pc		Filter□1set			
	Spoon□1pc		Mounting resin□1kg(2.2lb)			Water pump□1set		
	Pipe clip□4pcs		Copper fitting□1pc		Spacer(E3)□2pcs			
Option	Cylinder kit							

Note 1: Two molds can be produced at same times if option spacer.

Note 2: Special temperature requirement can be customized.

Note 3: Special shape and size requirements can be customized.

We reserve the right of changing design without notice

Parameter

Dimension

MA (Unit mm)

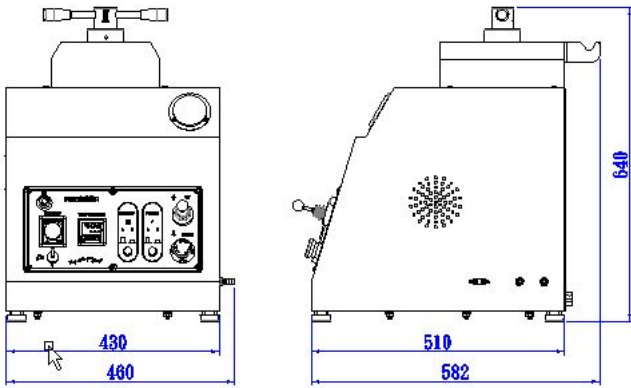

MA-E3 (unit mm)

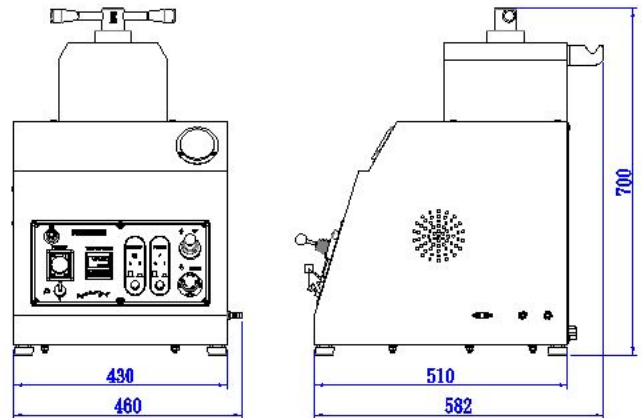

Heating/cooling graph line

Note:

1. Sample- \varnothing 32mmx20mm (t).
2. Testing results will be different according to weather condition, materials, sample sizes, and cylinder sizes.

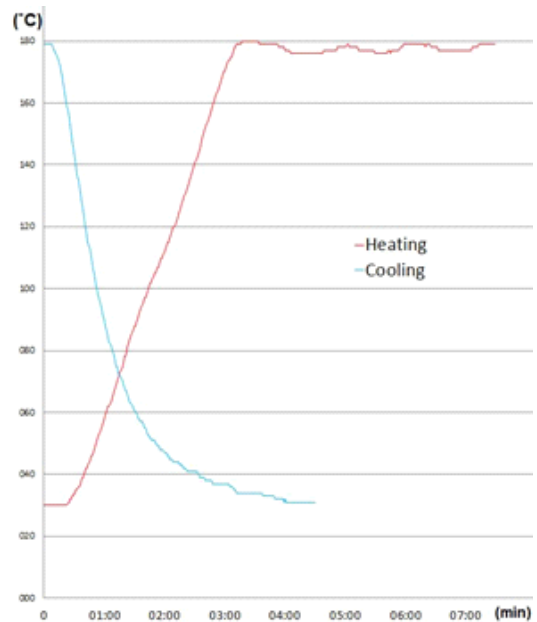

Mold size

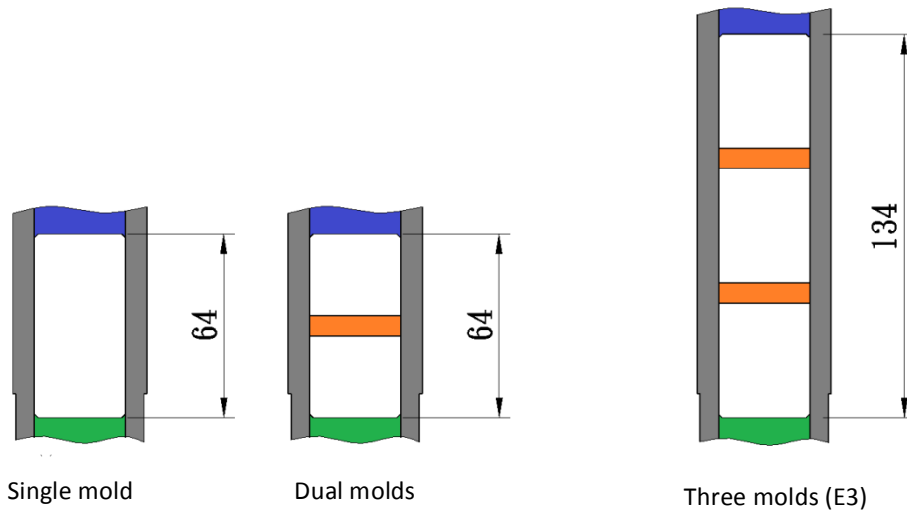

	Mounting size (mm)	Mounting height (mm)	Mounting powder weight (g)	Mold qty.	Mold volume (mm ³)
Single mold	Ø25	21	18	1	10303
	Ø32	21	30	1	16880
	Ø40	21	47	1	26376
	Ø50	21	75	1	41213
Dual mold	Ø25	14	12x2	2	6869
	Ø32	14	22x2	2	11253
	Ø40	14	31x2	2	17584
	Ø50	14	49x2	2	27427
Three molds (E3)	Ø25	18	16x3	3	8831
	Ø32	18	25x3	3	14469
	Ø40	18	40x3	3	22608
	Ø50	18	63x3	3	35325

Parameter

Mounting pressure comparison table

	Metric system (Kg/cm ²)	British system (psi)
Pressure adding	60	853
Max. pressure	100	1421

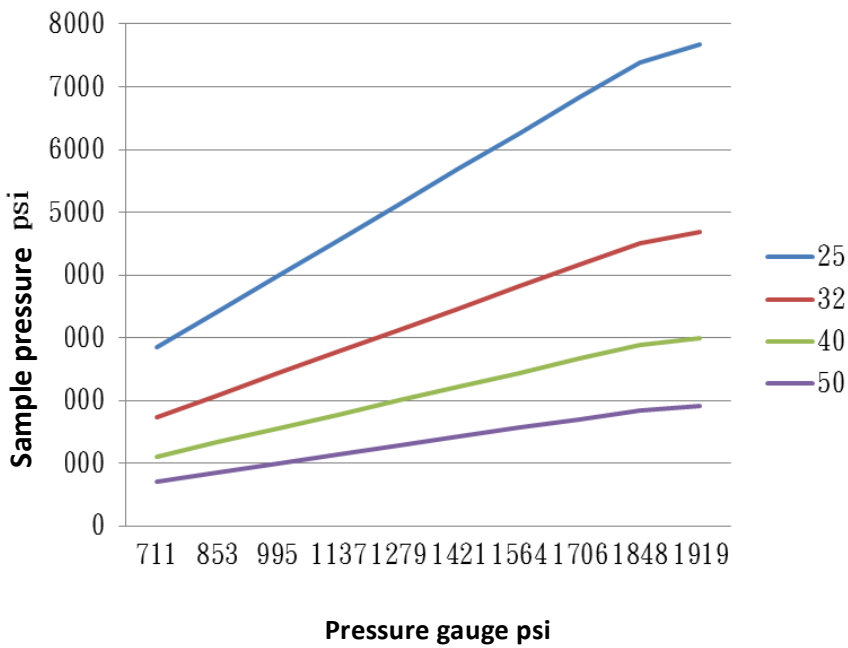
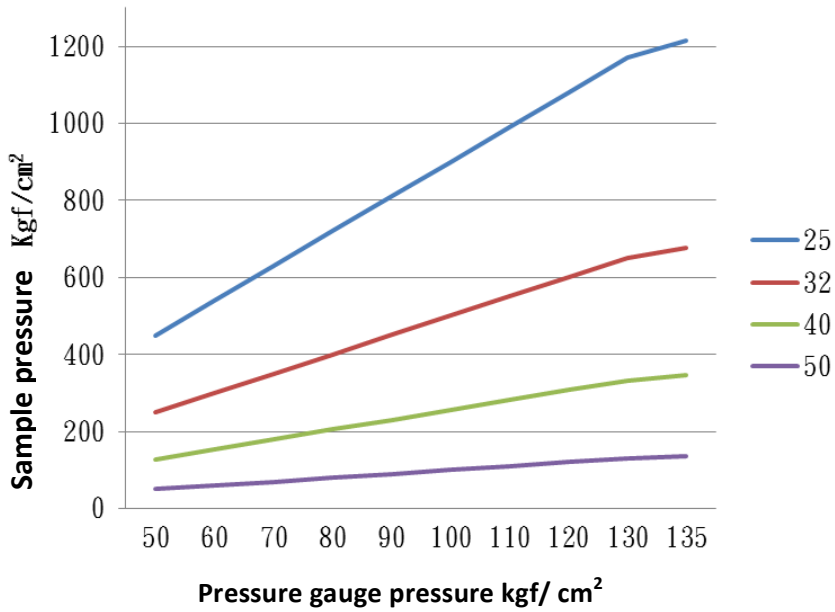

Consumables

Clear transparent acrylic hot mounting resin

	Order no.	S030109	1 kg
		S030108	2 kg
		S030109-1	5 lb (2.27kg)

Conductive mounting resin, thermosetting, Phenol- formaldehyde resin

	Order no.	S030106	1 lb (0.45kg)
--	-----------	---------	---------------

Black bake lite hot mounting resin

	Order no.	S03001	Black-25 kg
		S03001-1	Black-1 kg
		S03002	Brown-25 kg
		S03002-1	Brown-1 kg
		S03002-2	Brown-2 kg
		S03003	Green-25 kg
		S03003-1	Green-1 kg
		S03004	Red-25 kg
		S03004-1	Red-1 kg



*Perfect Surface.
Always*

Cutting / Mounting / Grinding & Polishing / Spin Coater

PRECISION SURFACES INTERNATIONAL, INC.

922 Ashland St., Houston, TX 77008 USA

Tel: (713)426-2220

<http://www.psidragon.com>

www.psimetallography.com

E-mail: info@psidragon.com

Agent

All PSI machines
are manufactured
for us by Top
Tech Machines
Co., Ltd.



We reserve the right to change design without notice.

NO.A16-01